

DC11383 Fuel Selector Valve Assembly

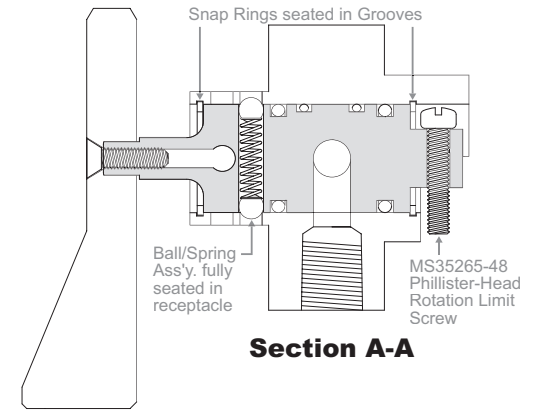
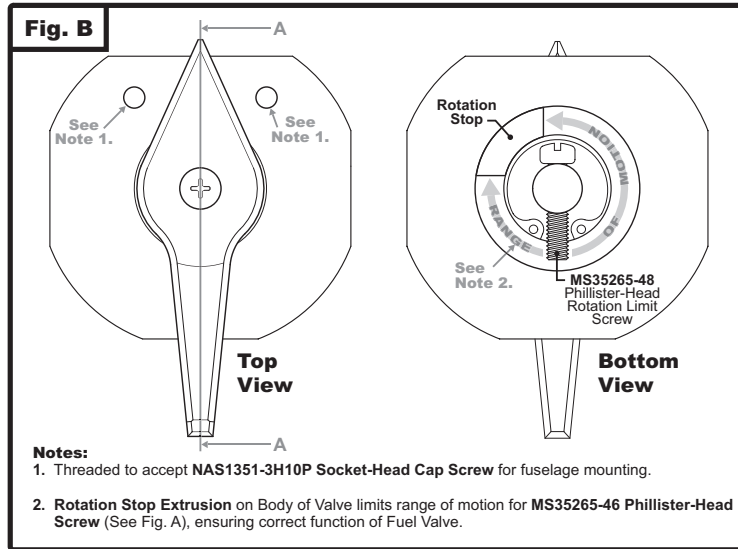
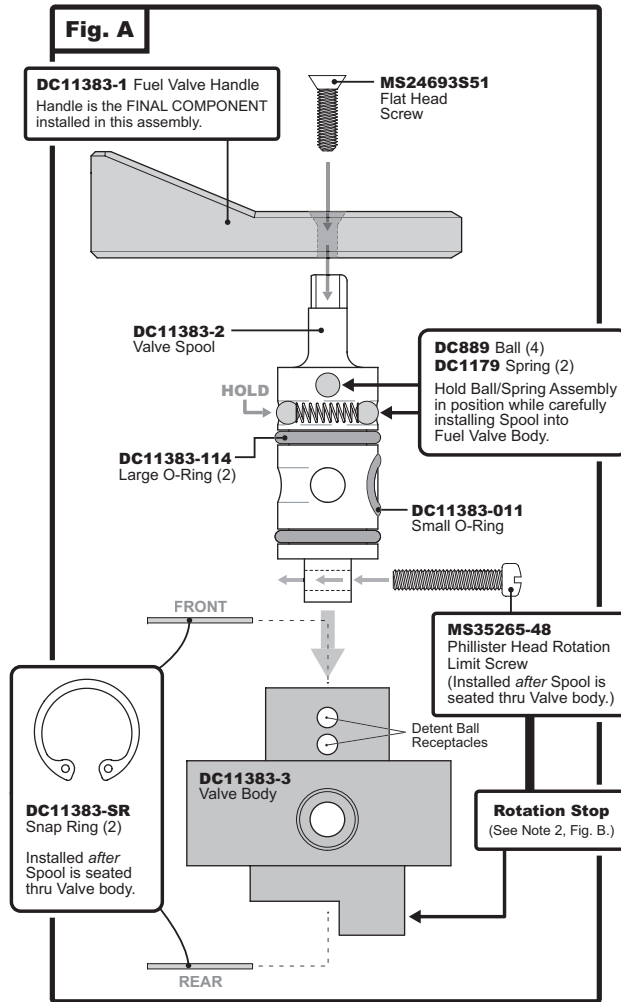

- Ensure that all components noted in figure A are clean of any contamination prior to assembly of DC11383 Fuel Selector Valve. Lubricate the bore of DC11383-3 Valve Body and DC11383-2 Valve Spool with Lubriplate #105 Motor Assembly Grease.
- Install DC11383-114 and DC11383-011 O-Rings onto DC11383 Spool at positions shown in figure A.
- The Spool has two spring bores at 90° to one another. Insert one DC1179 Spring and two DC889 Balls into each bore (See fig. A).
- Holding Ball/Spring Assemblies in place, carefully insert Valve Spool into Valve Body as shown in Figure A. The Spool is correctly seated within Valve Body once both sets of Ball/Springs "snap" into their corresponding receptacles in upper section of Valve Body (See Section A-A).
- Install DC11383-SR Snap Rings into upper and lower snap ring grooves on Valve Body to secure Spool/Body Assembly. (See Figure A and Section A-A.)
- With Spool seated and secured in Valve Body, install MS35265-48 Phillister-Head Rotation Locking Screw into bottom section of Spool, applying Loctite 242 Thread Locker to screw, and positioning as shown in figures A & B. Install DC11383-1 Handle onto Spool with MS24693S51 Flat Head Screw. Check for correct operation of completed assembly - rotate Handle, observing "Ball Detent Action" indicating positive location for each Valve position.

MFG PRACTICES / DCA GENERAL MECHANICAL - 1
ALL DATA PROPRIETARY TO DAKOTA CUB AIRCRAFT

Part No.	No. Req.	Size	Description	Material
10	1	8-32 x 7/8	Screw - Phillister Head Rotation Limit	
9	1	8-32 x 5/8	Screw - Flat Head	
8	2		Spring - Fuel Valve	
7	2		Snap Ring - Fuel Valve	
6	2		O-Ring (large) - Fuel Valve	
5	1		O-Ring (small) - Fuel Valve	
4	4	3/16	Ball - Stainless Steel	
3	1		Body - Fuel Valve	
2	1		Spool - Fuel Valve	
1	1		Handle - Fuel Valve	

Unless Otherwise Specified Tolerances -	Scale: 1=1
Angles = ± 2°	MFG Practices - DCA Spec. No. 9 - Finish - DCA Spec. No. 10
Fractions = ± 1/32	
.0 = ± .032	
.00 = ± .020	
.000 = ± .010	

LET.	REVISION	DATE	BY

DWG. DATE	MDE 5-03-07	Check DATE	MDE 5-03-07	Drawing No.	DC11383-ICA
-----------	-------------	------------	-------------	-------------	-------------

DAKOTA CUB AIRCRAFT Box 797
 Brandon, SD

DC11383 Fuel Selector Valve Installation

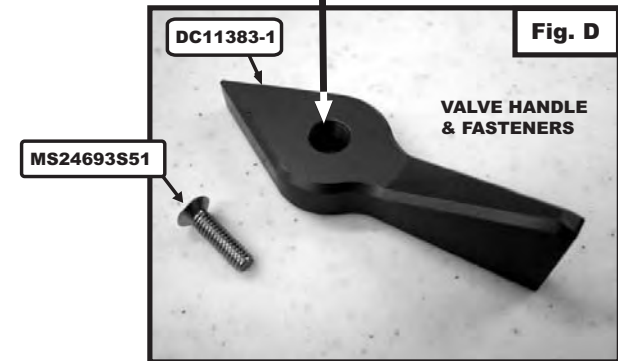
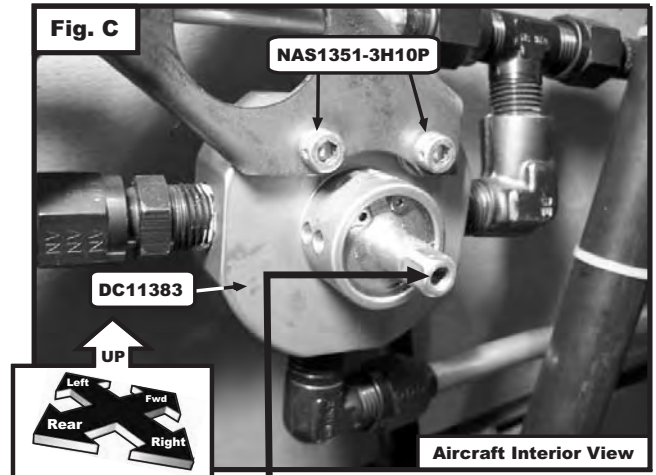
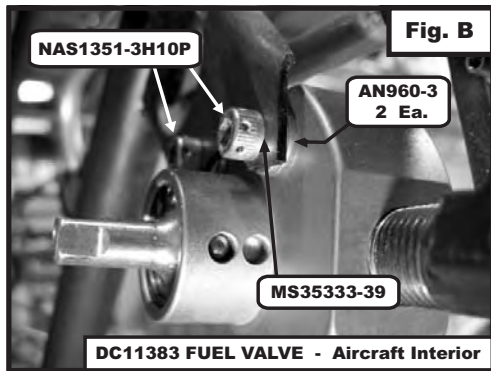
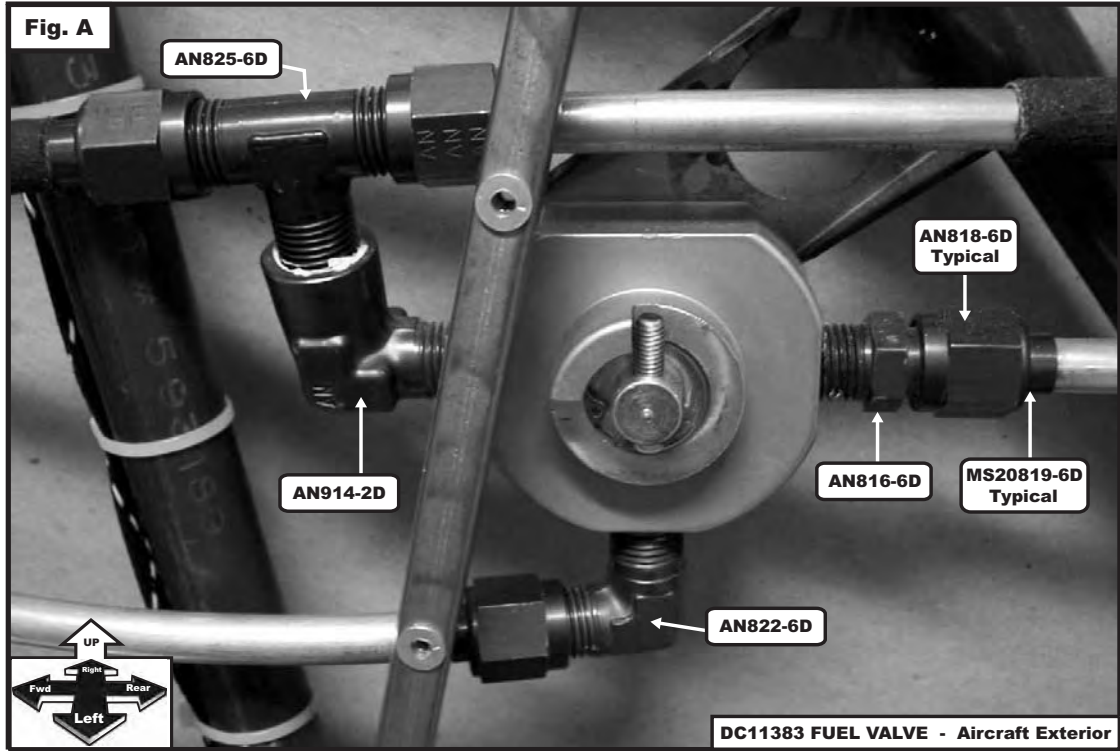

Notes:

1. All NPT Joints sealed with non-hardening thread sealing compound suitable for use with aviation and automotive grade fuels.
2. Primary locking for valve cap screws - MS35333-39 Washer. Alternate locking method - safety wire per AL43.13 between NAS 1351-3H10P Cap Screws.

12	MS24693S51	1		Screw - Flat Head
11	MS20995	1	.020 Stainless	Safety Wire
10	MS35333-39	2		Internal Star Washer
9	NAS1351-3H10P	2		Socket Head Cap Screw
8	AN818-6D	4		Tube Nut
7	MS20819-6D	4		Sleeve
6	AN914-2D	1		Elbow
5	AN816-6D	1		Nipple - Flare to Pipe
4	AN822-6D	1		Elbow
3	AN960-3	4		Washer
2	DC11383-1	1		Handle
1	DC11383	1		Fuel Valve Assembly
	Part No.	No. Req.	Size	Description
				Material

Scale: 1=1
MFG Practices - DCA Spec. No. 9 - Finish - DCA Spec. No. 10



MFG PRACTICES / DCA GENERAL MECHANICAL - 1			
ALL DATA PROPRIETARY TO DAKOTA CUB AIRCRAFT			
Unless Otherwise Specified Tolerances -			
Angles = ± 2°			
Fractions = ± 1/32	LET.	REVISION	DATE BY
.0 = ± .032	DAKOTA CUB AIRCRAFT Box 797 Brandon, SD		
.00 = ± .020			
.000 = ± .010			

FUEL VALVE ICA			
DWG. MDE	Check - MDE	Drawing No. -	
DATE 5-03-07	DATE 5-03-07	DC11383-ICA	
Sheet 2 of 3			

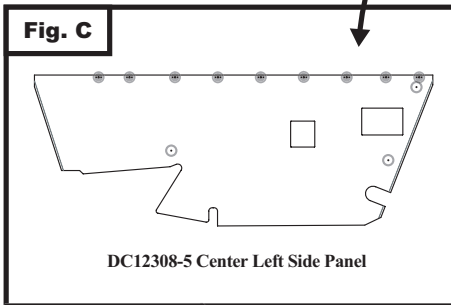
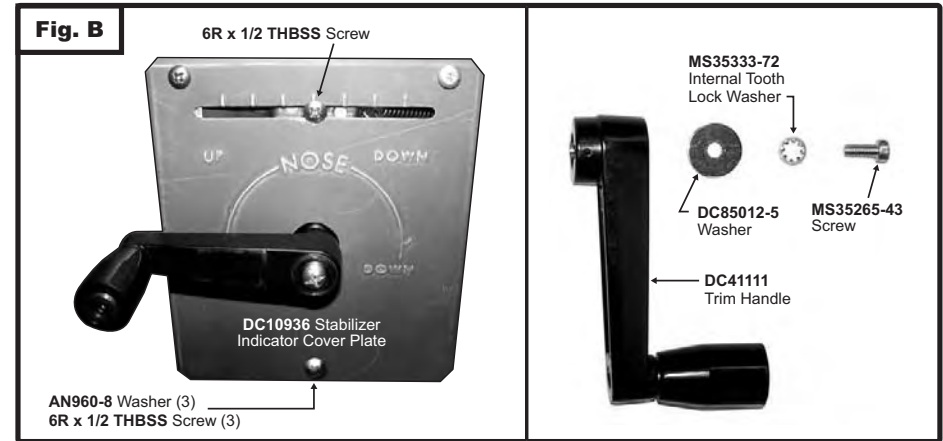
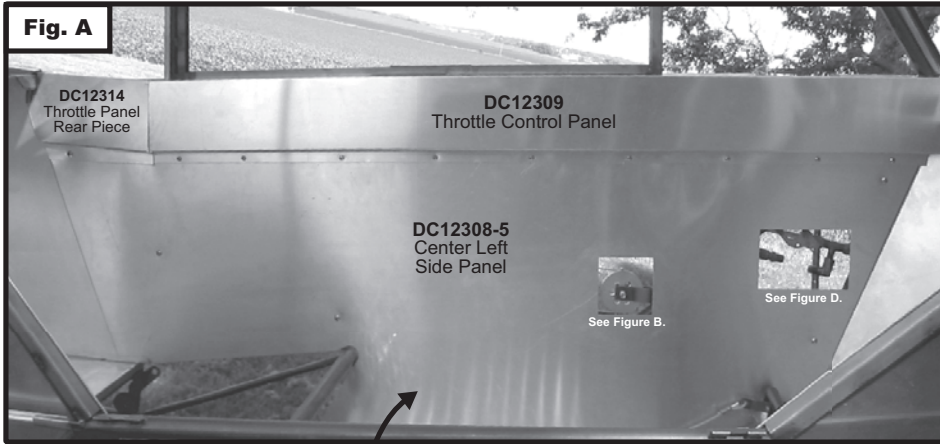

KEY	REQUIRED FASTENERS	QTY
○	8R x 1/2 THBSS #8 Screw	3
	AN960-8 Washer	3
●	8-32 x 1/2 THSS #8 Screw	12
	AN960-8 Washer	12

NOTES:
Upper edge of DC12308-5 Center Left Side Panel is overlapped by DC12309 Throttle Control Panel and DC12314 Throttle Panel Rear Piece. (See Fig. A)

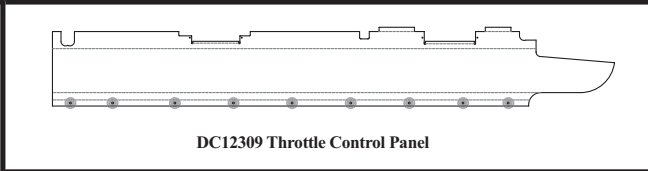
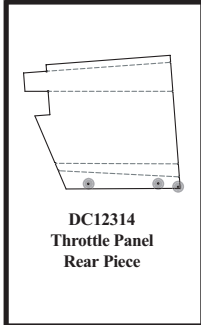

DC11383 Fuel Selector Valve Access from Aircraft Interior

- A. Access to DC11383 Fuel Selector Valve is achieved by unfastening the Fuel Valve Handle and removing the Fuel Valve Cover Plate from the Center Left Side Panel. (Refer to Figs. A & D.)
- B. If further access is required, the Trim Handle and Stabilizer Indicator Cover Plate must be removed (See Fig. B) so that DC12314 Throttle Panel Rear Piece, DC12309 Throttle Control Panel, DC12308-5 Center Left Side Panel can be removed as well (See Figs. A & C).

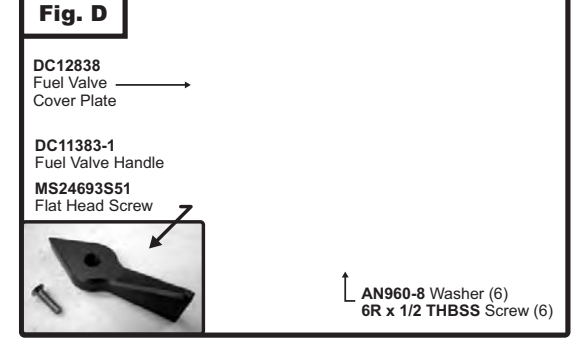

15	8-32 x 1/2 THSS	12		#8 Screw - Truss Head, Stainless Steel
14	8R x 1/2 THBSS	3		#8 Screw - Truss Head, Blunt, Stainless Steel
13	6R x 1/2 THBSS	10		#6 Screw - Truss Head, Blunt, Stainless Steel
12	AN960-8	24		Washer
11	MS35333-72	1		Lock Washer - Internal Tooth
10	MS35265-43	1		Screw - Phillister Head
9	MS24693S51	1		Screw - Flat Head
8	DC10936	1		Plate - Stabilizer Indicator Cover
7	DC11383-1	1		Handle - Fuel Valve
6	DC12838	1		Plate - Fuel Valve Cover
5	DC41111	1		Handle - Trim
4	DC85012-5	1		Washer
3	DC12309	1		Throttle Control Panel
2	DC12308-5	1		Center Left Side Panel
1	DC12314	1		Throttle Panel Rear Piece
	Part No.	No. Req.	Size	Description
				Material

MFG PRACTICES / DCA GENERAL MECHANICAL - 1

ALL DATA PROPRIETARY TO DAKOTA CUB AIRCRAFT

Unless Otherwise Specified
Tolerances -
Angles = ± 2°
Fractions = ± 1/32
0 = ± .032
.00 = ± .020
.000 = ± .010

LET	REVISION	DATE	BY

DAKOTA CUB AIRCRAFT Box 797
Brandon, SD

Scale: 1=1
MFG Practices - DCA Spec. No. 9 - Finish - DCA Spec. No. 10

FUEL VALVE ICA

DWG.	MDE	Check -	MDE	Drawing No. -
DATE	5 - 03 - 07	DATE	5 - 03 - 07	DC11383-ICA

Sheet 3 of 3